



File No.:E75887



File No.:R 50216304



FEATURES

- Highly reliable, low cost
- Miniature size & large switch capacity up to 20A
- High dielectric strength type
- Fully Sealed

CONTACT RATINGS

Contact Arrangement	1A, 1B, 1C
Contact Resistance	50mΩ (1A 24VDC)
Contact Material	AgSnO, AgCdO, Gold FLash
Contact Rating(Resistive)	3A 120VAC/28VDC 6A 120VAC/28VDC 12A 120VAC/28VDC 15A/120VAC 20A/120VAC
Max. Switching Voltage	277VAC/28VDC
Max. Switching Current	20A
Max. Switching Power	5540VA/560W
Mechanical Life	1×10 ⁷ operations
Electrical Life	1×10 ⁵ operations

CHARACTERISTICS

Insulation Resistance		≥100MΩ (at 500VDC)
Dielectric Strength	Between coil & contacts	1500VAC 1min
	Between open contacts	750VAC 1min
Operate time (at nomi. volt.)		≤8ms
Release time (at nomi. volt.)		≤5ms
Humidity		45% ~ 85% RH
Ambient temperature		Class B:-40°C~85°C; Class F:-40°C~105°C
Shock Resistance	Functional	98m/s ²
	Destructive	980m/s ²
Vibration resistance		10Hz to 55Hz 1.5mm DA
Unit weight		Approx. 12g
Construction		Sealed, Covered

Notes:1) The data shown above are initial values.

2) Please find coil temperature curve in the characteristic curved below.

This datasheet is for customers' reference. All the specifications are subject to change without notice.

ORDERING INFORMATION

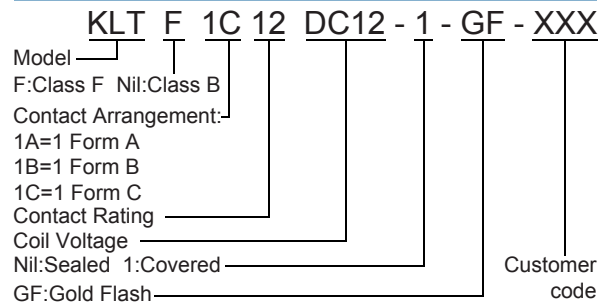

COIL DATA

at 20°C

3A, 6A, 12A, 15A

Nominal Voltage VDC	Pick-up Voltage (Max.) VDC	Drop-out Voltage (Min.) VDC	Max. Allowable Voltage VDC	Coil Resistance Ω±10%
3	2.25	0.3	3.9	25
5	3.75	0.5	6.5	70
6	4.50	0.6	7.8	100
9	6.75	0.9	11.7	225
12	9.00	1.2	15.6	400
24	18.0	2.4	31.2	1600
48	64.0	4.8	62.4	6400

20A

Nominal Voltage VDC	Pick-up Voltage (Max.) VDC	Drop-out Voltage (Min.) VDC	Max. Allowable Voltage VDC	Coil Resistance Ω±10%
3	2.25	0.3	3.9	20
5	3.75	0.5	6.5	55
6	4.50	0.6	7.8	80
9	6.75	0.9	11.7	180
12	9.00	1.2	15.6	320
24	18.0	2.4	31.2	1280
48	64.0	4.8	62.4	5120



RELAYS & ELECTRONICS INT'L CORP.

* SINCE 1976 *

TEL:(516) 328-9292 FAX:(516)326-9125 www.hascorelays.com email:info@hascorelays.com

RELAYS

KLT SERIES

SPDT

3,6,12,15,20 Amp

COIL

Coil Power	3A-15A: 360mW
	20A: 450mW

SAFETY APPROVAL RATINGS

UL&CUL	Resistive	3A 120VAC/28VDC, 6A 120VAC/28VDC 12A 120VAC/28VDC, 15A/120VAC 20A/120VAC
	N.O. Only, Single Pole	10A 12VDC Tungsten, 1500W 277VAC Ballast 15A(1700W) 120VAC Tungsten, 1/2hp 120VAC
TüV		6A 250VAC/28VDC

OUTLINE DIMENSIONS, WIRING DIAGRAM AND PC BOARD LAYOUT.

Unit: inch(mm)

Outline Dimensions

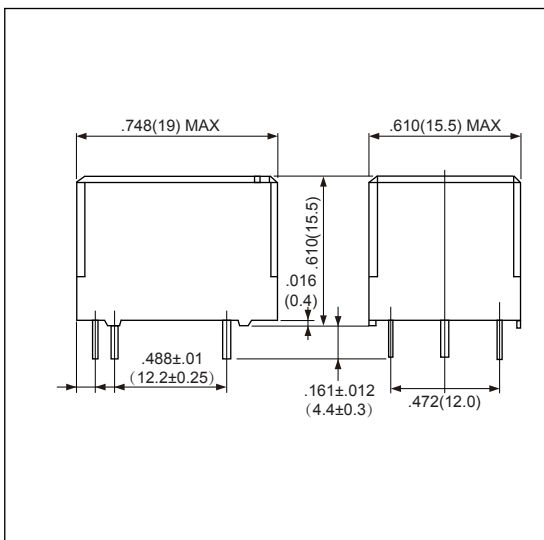

Wiring Diagram (Bottom view)

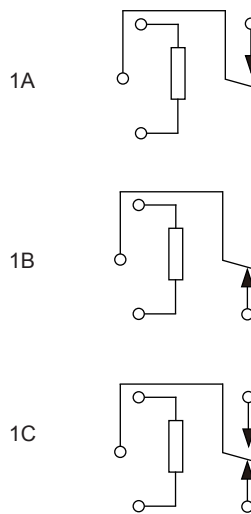

PCB Layout (Bottom view)

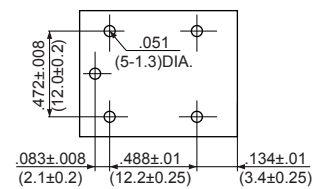

Remark:1) In case of no tolerance shown in outline dimension: outline dimension $\leq 1\text{mm}$, tolerance should be $\pm 0.2\text{mm}$; outline dimension $> 1\text{mm}$ and $\leq 5\text{mm}$, tolerance should be $\pm 0.3\text{mm}$; outline dimension $> 5\text{mm}$, tolerance should be $\pm 0.4\text{mm}$.
2) The tolerance without indicating for PCB layout is always $\pm 0.1\text{mm}$.

CHARACTERISTIC CURVES

MAXIMUM SWITCHING POWER

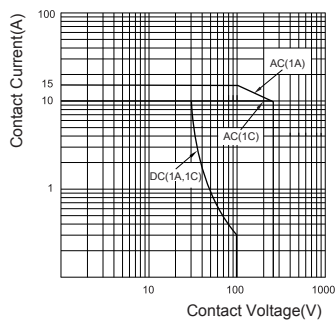

ENDURANCE CURVE

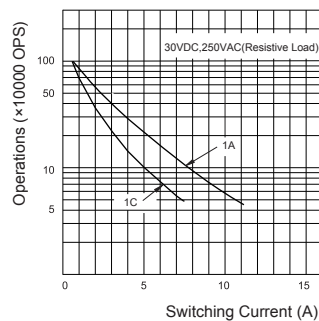

COIL TEMPERATURE RISE

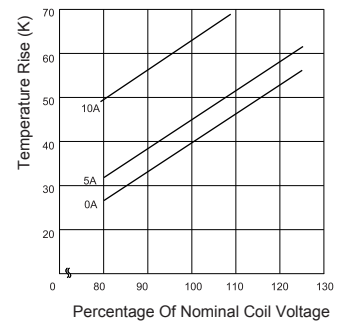

This datasheet is for customers' reference. All the specifications are subject to change without notice.